

CLASP LOCKING TYPE

密锁定螺帽

■ YSK

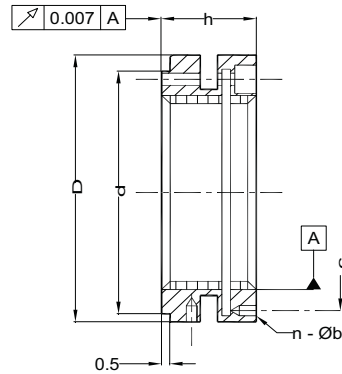
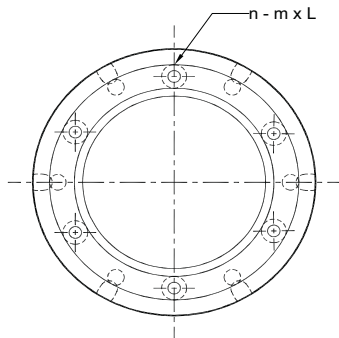

• Dimensions / 尺寸

Unit / 单位 : mm

Product Number 产品编号	D	h	d	n	b	c	n-mxL	Max. Torque 最大扭矩 (N.m)
YSK M16X1.5	34	18	29	4	4	24	4 - M4 X 12	3.5
YSK M17X1	37		32			26		
YSK M18X1.5	38		33			28		
YSK M20X1	40		35			30		
YSK M20X1.5						32		
YSK M22X1.5	42		37			34		
YSK M24X1.5	44	39						
YSK M25X1.5	45	20	40	5	35	4 - M4 X 14		
YSK M26X1.5			43		37			
YSK M28X1.5			46		39			
YSK M30X1.5	48	22	45	5	41	4 - M4 X 16		
YSK M32X1.5	50		47		44			
YSK M35X1.5	53		50		47			
YSK M38X1.5	56		53		49			
YSK M40X1.5	58		55		51			
YSK M42X1.5	60		63		57			
YSK M45X1.5	68	25	65	6	58	6 - M4 X 18		
YSK M48X1.5			66		60			
YSK M50X1.5			69		62			
YSK M52X1.5	72	26	68	6	65	6 - M5 X 20		
YSK M55X1.5			71		70			
YSK M55X2	75	77	72					
YSK M58X1.5	82	28	79	6	75			
YSK M60X1.5			84		77			
YSK M60X2	86	28	82	7	80			
YSK M62X1.5			84		82			
YSK M65X1.5	88	28	87	7	82			
YSK M65X2			89		84			
YSK M68X1.5	93	32	91	8	84			
YSK M70X1.5			95		87			
YSK M70X2	97	32	94	8	87			
YSK M72X1.5			99		95			
YSK M75X1.5	100	32	103	8	95			
YSK M75X2			108		100			
YSK M80X2	110	32	108	8	100			
YSK M85X2			113		105			
YSK M90X2	120	32	113	8	105			
YSK M95X2			118		110			



• Dimensions / 尺寸

Unit / 单位 : mm

Product Number 产品编号	D	h	d	n	b	c	n-mxL	Max. Torque 最大扭矩 (N.m)		
YSK M100X2	130	32	123	6	8	115	6 - M6 X 22	8.0		
YSK M105X2	135		128			120				
YSK M110X2	140		133			125				
YSK M115X2	145	34	137			130	6 - M6 X 25			
YSK M120X2	155	36	146			136				
YSK M125X2	160		150			140				
YSK M130X2	165		155	148						
YSK M140X2	180	38	168	8	10	160	8 - M6 X 25	18.0		
YSK M150X2	190		178			170				
YSK M160X3	205	40	190			8	10		178	8 - M8 X 30
YSK M170X3	215		200						193	
YSK M180X3	230		213						205	
YSK M190X3	240		223						215	
YSK M200X3	250		230	223						

ORDERING EXAMPLE

订购例子

