

FLANK LOCKING TYPE

牙腹锁定型

■ YSF

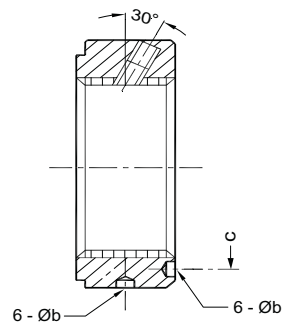
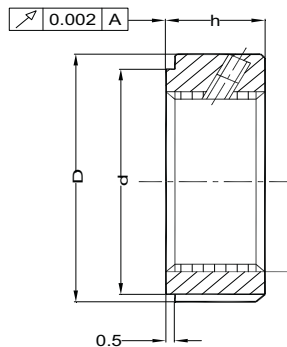
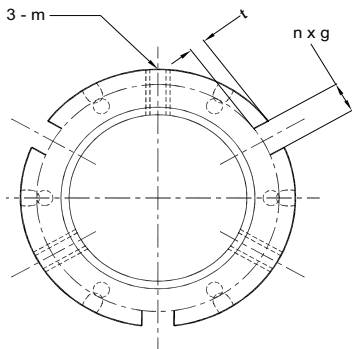

• Dimensions / 尺寸

Unit / 单位 : mm

Product Number 产品编号	D	h	d	n x g / b	t / c	M	Max. Torque 最大扭矩 (N.m)	
YSF M14X1.5	30	14	25	3 X 4 / -	2	-	4.5	
YSF M15X1					2	-		
YSF M16X1.5					2	-		
YSF M17X1	32	16	27		2	-		
YSF M18X1.5					2	-		
YSF M20X1					2	-		
YSF M20X1.5	38	16	33	3 X 5 / -	2	-	8.0	
YSF M22X1.5					2	-		
YSF M24X1.5					2	-		
YSF M25X1.5	40	18	35		2	-		
YSF M27X1.5					2	-		
YSF M30X1.5					2	-		
YSF M33X1.5	45	18	40	3 X 6 / -	2	-	18.0	
YSF M35X1.5					2	-		
YSF M36X1.5					2	-		
YSF M39X1.5	52	18	45		3 X 7 / Ø6	2		-
YSF M39X1.5						2		-
YSF M40X1.5						2		-
YSF M42X1.5	58	20	56	3 X 8 / Ø6		2.5	-	
YSF M45X1.5						2.5	-	
YSF M48X1.5						2.5	-	
YSF M50X1.5	70	22	64		3 X 8 / Ø7	2.5	-	
YSF M52X1.5						2.5	-	
YSF M55X2						63	-	
YSF M56X2	75	22	68	6 X 8 / Ø7		65	-	
YSF M60X2						65	-	
YSF M64X2						70	-	
YSF M65X2	85	24	78		6 X 8 / Ø7	75	-	
YSF M68X2						75	-	
YSF M70X2						81	-	
YSF M72X2	94	24	86	6 X 10 / Ø7		81	-	
YSF M75X2						83	-	
YSF M76X2						87	-	
YSF M80X2	105	26	96		6 X 10 / Ø7	87	-	
YSF M85X2						87	-	
YSF M90X2						93	-	
YSF M95X2	125	26	113	6 X 10 / Ø7		98	-	
YSF M95X2						105	-	
YSF M95X2	125	26	113	6 X 10 / Ø7		110	-	



• Dimensions / 尺寸

Unit / 单位 : mm

Product Number 产品编号	D	h	d	n x g / b	t / c	M	Max. Torque 最大扭矩 (N.m)
YSF M100X2	130	26	118	6 X 10 / Ø7	4	M8	18.0
YSF M105X2	140	28	125				
YSF M110X2	145		132				
YSF M115X2	150		137				
YSF M120X2	155		30				
YSF M125X2	160	147					
YSF M130X2	165	152					
YSF M135X2	175	160					
YSF M140X2	180	32	165	6 X 14 / Ø8	6	M12	60.0
YSF M145X2	190		175				
YSF M150X2	195		180				
YSF M155X3	200		180				
YSF M160X3	210	34	190	6 X 16 / Ø8	7	M12	60.0
YSF M165X3	210		190				
YSF M170X3	220		200				
YSF M180X3	230		205				
YSF M190X3	240	36	215	6 X 16 / Ø8	7	M12	60.0
YSF M200X3	250		225				

ORDERING EXAMPLE

订购例子

