

RADIAL LOCKING TYPE

径向锁定型

■ YSR

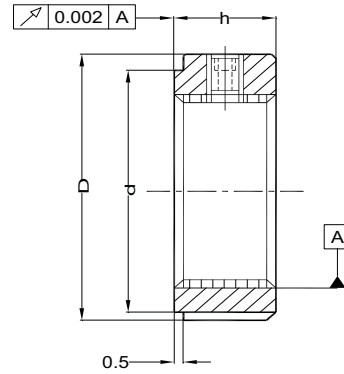
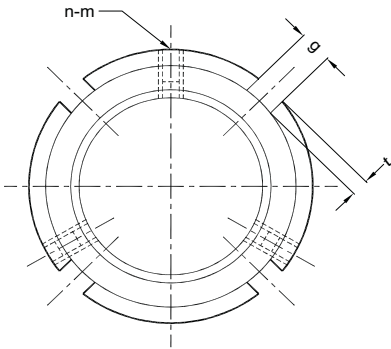

• Dimensions / 尺寸

Unit / 单位 : mm

Product Number 产品编号	D	h	d	t	n - m	g	Max. Torque 最大扭矩 (N.m)			
YSR M6X0.5	16	8	11	2	2 - M4	3	3.5			
YSR M8X0.75			13							
YSR M10X0.75	18	8	16							
YSR M10X1			21							
YSR M12x1	20	10	23					2 - M5	4	4.5
YSR M12X1.25			25							
YSR M14X1.5	25	10	27							
YSR M15X1			30							
YSR M16X1.5	28	10	30		3 - M5	5	8.0			
YSR M17X1			35							
YSR M18X1.5	30	12	33							
YSR M20X1			37							
YSR M20X1.5	32	12	40	2.5	3 - M6	6	18.0			
YSR M22X1.5			45							
YSR M24X1.5	35	14	47							
YSR M25X1.5			49							
YSR M27X1.5	42	14	52					3	7	18.0
YSR M30X1.5			56							
YSR M33X1.5	58									
YSR M35X1.5	52	16	59		3 - M8	8	18.0			
YSR M36X1.5			62							
YSR M39X1.5	55	16	64							
YSR M40X1.5			66							
YSR M42X1.5	62	18	68					3.5	8	18.0
YSR M45X1.5			70							
YSR M48X1.5	65	18	73							
YSR M50X1.5			77							
YSR M52X1.5	70	18	78	3.5	8	18.0				
YSR M55X2			84							
YSR M56X2	75	18	86							
YSR M60X2			88							
YSR M64X2	80	18	90							
YSR M65X2			92							
YSR M68X2	92	18	92							
YSR M70X2										
YSR M72X2	95	18								
YSR M75X2										
YSR M76X2	100									



• Dimensions / 尺寸

Unit / 单位 : mm

Product Number 产品编号	D	h	d	t	n - m	g	Max. Torque 最大扭矩 ( N.m )
YSR M80X2	105	18	96	3.5	3 - M8	8	18.0
YSR M85X2	110		102				
YSR M90X2	120	20	108	4		10	
YSR M95X2	125		113				
YSR M100x2	130		118				
YSR M105X2	140	22	125	5		12	
YSR M110X2	145		132				
YSR M115X2	150		137				
YSR M120X2	155	24	142	6		14	
YSR M125X2	160		147				
YSR M130X2	165		152				
YSR M135X2	175	26	160	7	16		
YSR M140X2	180		165				
YSR M145X2	190		175				
YSR M150X2	195	28	180	8	18		
YSR M155X3	200		180				
YSR M160X3	210		190				
YSR M165X3	210	30	190	3 - M10	35.0		
YSR M170X3	220		200				
YSR M180X3	230		205				
YSR M190X3	240	32	215	3 - M12	60.0		
YSR M200X3	250		225				

ORDERING EXAMPLE

订购例子

