

HIGH TORQUE SERVOFLEX COUPLING

高扭矩膜片联轴器

■ CPA

Steel Plain Type / 普通钢铁类型

■ CPD

Steel Clamp Type / 钢铁固定螺钉类型

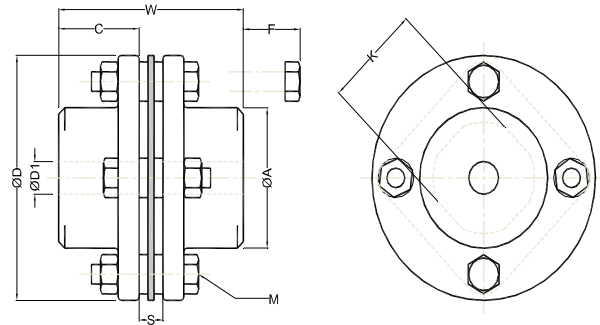

CPA

• Dimensions / 测量尺寸

Unit / 单位 : mm

Product Number 产品编号	D	A	W	C	S	F	M	K	Stock Bores 标准孔径	
									Min D ₁	Max D ₁
CPA-68	68	40	56	25	6	13	M6 x 4	28	7	25
CPA-82	82	54	56.2	25	6.2	13	M6 x 4	34	12	35
CPA-94	94	58	69.6	30	9.6	23	M8 x 4	40	12	38
CPA-104	104	68	76	33	10	20	M8 x 4	42	20	42
CPA-126	126	78	91	40	11	25	M10 x 4	50	20	50
CPA-144	144	88	102	45	12	20	M10 x 4	57	20	60
CPA-168	168	104	164	75	14	-	M10 x 6	108	30	70
CPA-180	180	120	176	80	16	-	M10 x 6	115	30	85

Unit / 单位 : mm

Product Number 产品编号	D	A	W	C	S	F	M	M1	Stock Bores 标准孔径 D ₁ x D ₂	
									Min D ₁	Max D ₂
CPD-68	68	40	56	25	6	-	M6 x 4	M6 x 4	12	20
CPD-82	82	54	66.2	30	6.2	-	M6 x 4	M6 x 4	15	30
CPD-94	94	58	79.6	35	9.6	-	M8 x 4	M6 x 6	20	35
CPD-104	104	68	90	40	10	-	M8 x 4	M8 x 4	20	38

Product No. 产品编号	Stock Bores (D ₁ x D ₂) Tolerance H8 / 标准孔径公差 H8												
	Ø12	Ø15	Ø16	Ø19	Ø20	Ø22	Ø24	Ø25	Ø28	Ø30	Ø32	Ø35	Ø38
CPD-68	•	•	•	•	•								
CPD-82		•	•	•		•				•			
CPD-94					•		•	•	•	•	•	•	
CPD-104					•		•	•		•	•	•	•

• Non-standard shaft bores and keyways are machined on request. Please contact us.
可以制造非标准轴孔径。请联系我们。

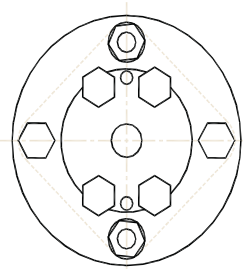
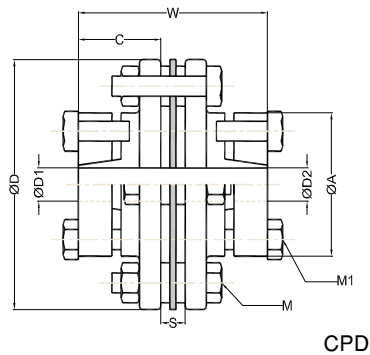

• Specifications / 规格

Product Number 产品编号	Rated Torque 常用扭矩 (N.m)	Max Rotational Frequency 最高回转数 (min ⁻¹)	Spring Constant 弹簧定数 (N.m/rad)	Axial Spring Constant 轴向弹簧定数 (N/mm)	Errors of Shaft End Play 容许轴向位差 (mm)	Moment of Inertia 惯性 (kg.m ²)	Max Shaft Load 最大轴装载 (N)	Mass 重量 (g)
CPA-68	39	20000	24525	45.1	+0.8 -0.8	0.0003	7.8	500
CPA-82	79	17000	80442	58.9	+1.0 -1.0	0.00087	22.6	1000
CPA-94	177	15000	147150	122.6	+1.2 -1.2	0.0016	44.1	1400
CPA-104	245	13000	235440	166.8	+1.4 -1.4	0.0026	58.9	2100
CPA-126	442	10000	412020	218.8	+1.6 -1.6	0.0065	107.9	3400
CPA-144	785	9000	706320	307.1	+1.8 -1.8	0.0099	196.2	4900
CPA-168	1177	5100	171675	54.0	+1.0 -1.0	0.0238	294.3	9600
CPA-180	1962	4800	233478	58.9	+1.0 -1.0	0.0365	490.5	12500

• Specifications / 规格

Product Number 产品编号	Rated Torque 常用扭矩 (N.m)	Max Rotational Frequency 最高回转数 (min ⁻¹)	Spring Constant 弹簧定数 (N.m/rad)	Axial Spring Constant 轴向弹簧定数 (N/mm)	Errors of Shaft End Play 容许轴向位差 (mm)	Moment of Inertia 惯性 (kg.m ²)	Max Shaft Load 最大轴装载 (N)	Mass 质量 (g)
CPD-68	39	20000	24525	45.1	+0.8 -0.8	0.0003	7.8	500
CPD-82	79	17000	80442	58.9	+1.0 -1.0	0.00087	22.6	1000
CPD-94	177	15000	147150	122.6	+1.2 -1.2	0.0016	44.1	1400
CPD-104	245	13000	235440	166.8	+1.4 -1.4	0.0026	58.9	2100

ORDERING EXAMPLE

订购例子

CPA - 82 - 15 x 30

Product No.
产品编号

D1

D2

(Only for CPD Series)
只限 CPD 系列